

IN PROCESS INSPECTION				
WELDING INSPECTION				
FITTER/WELDER:				
DIMENSIONAL VERIFICATION		YES	NO	
WELDING PROCEDURE:				
FILLER WIRE USED:				
WELDING GAS USED:				
NDT TEST OF LUGS		ACPT	RJCT	
100% VISUAL INSPECTION		ACPT	RJCT	
INSPECTED BY:		DATE:		
ACCESSORY REQUIREMENTS				
		YES	NO	CHK'D
SUPPORT LEGS				
SUPPORT PADS				
LIFTING LUGS				
BIRDSCREEN				
INSPECTED BY:		DATE:		
FINAL BLAST & PAINT INSPECTION				
SURFACE PREPERATION				
DATE		TIME		
AIR TEMP		METAL TEMP		
HUMIDITY		DEW POINT		
SURFACE PREPERATION				
SEE ATTACHED BLAST PROFILE RECORD				
FINISH APPLICATION				
DATE		TIME		
AIR TEMP		METAL TEMP		
HUMIDITY		DEW POINT		
PAINT BATCH #				
PAINTED BY:				
MASKED PROPERLY		YES	NO	
CORRECT COATING		YES	NO	
CORRECT COLOR		YES	NO	
ACTUAL DFT				
PAINT FINISH		ACPT	RJCT	
PAINT DEFECTS				
RUNS		YES	NO	
SAGS		YES	NO	
DRIPS/SQUIRTS		YES	NO	
OVERSPRAY		YES	NO	
HOLIDAY		YES	NO	
CORRECT DFT		YES	NO	
WELD SPLATTER		YES	NO	
CAULKING APPLIED		YES	NO	
INSPECTED BY:		DATE:		
SHIPPING INSPECTION				
HARDWARE		YES	NO	
VELOCITY TUBES		YES	NO	
PIEZOMETER TUBES		YES	NO	
FILTERS		YES	NO	
NAMES PLATES & LABELS		YES	NO	
BILL OF LADING		YES	NO	
SPECIAL SHIPPING INSTRUCTIONS		YES	NO	
WEATHER PROTECTION		YES	NO	
EXPORT CRATED		YES	NO	
INSPECTED BY:		DATE:		
FINAL Q.C. INSPECTION				
PHOTOS BEFORE PKG		YES	NO	
PHOTOS AFTER PKG		YES	NO	
APPROVED FOR SHIPMENT		YES	NO	
INSPECTED BY:		DATE:		
COMMENTS:				
F-AA-1501-01 REV B 05.27.09				

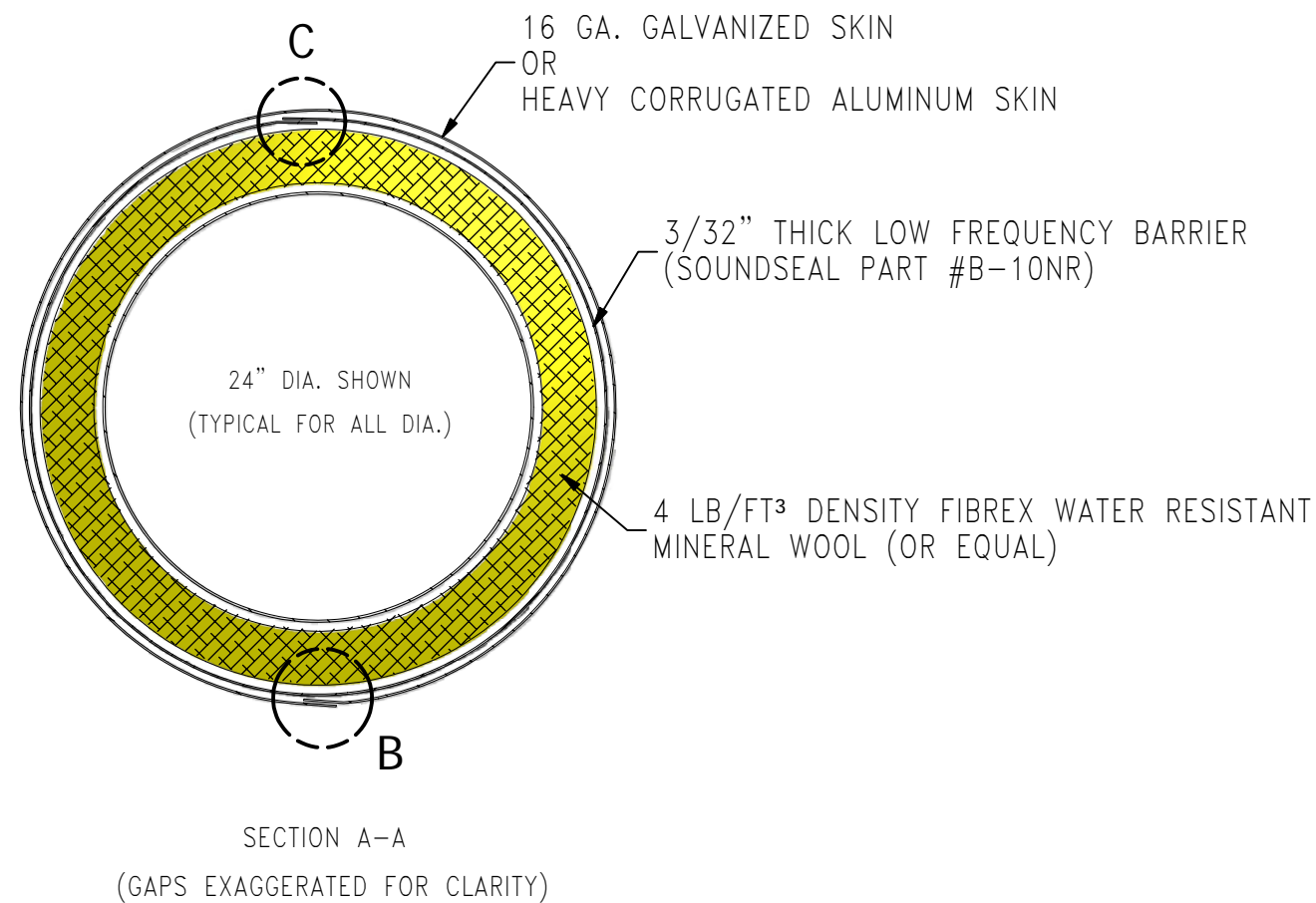
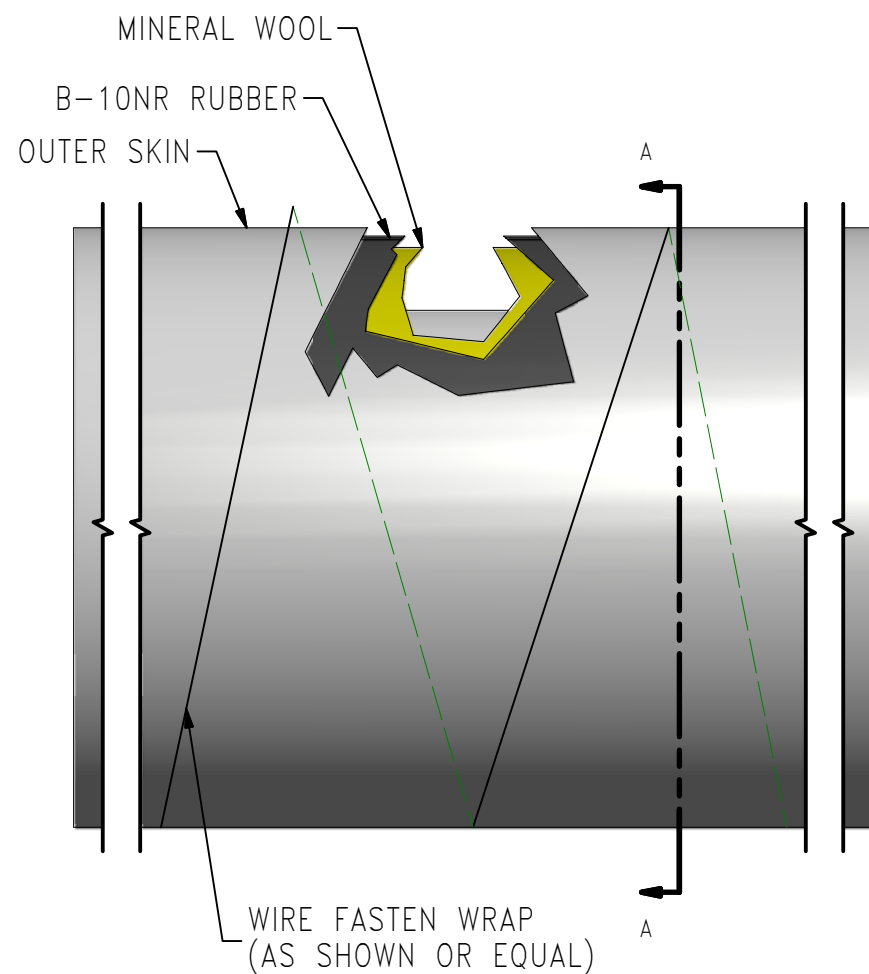
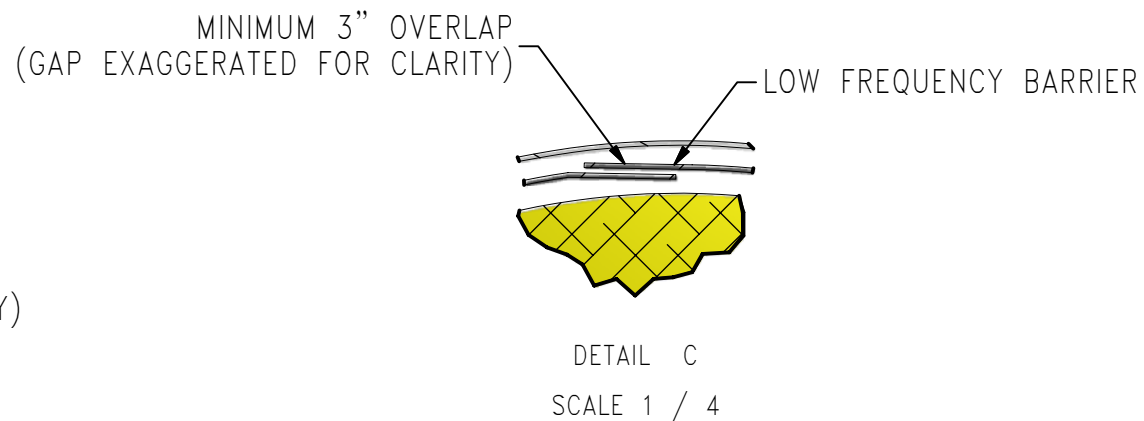
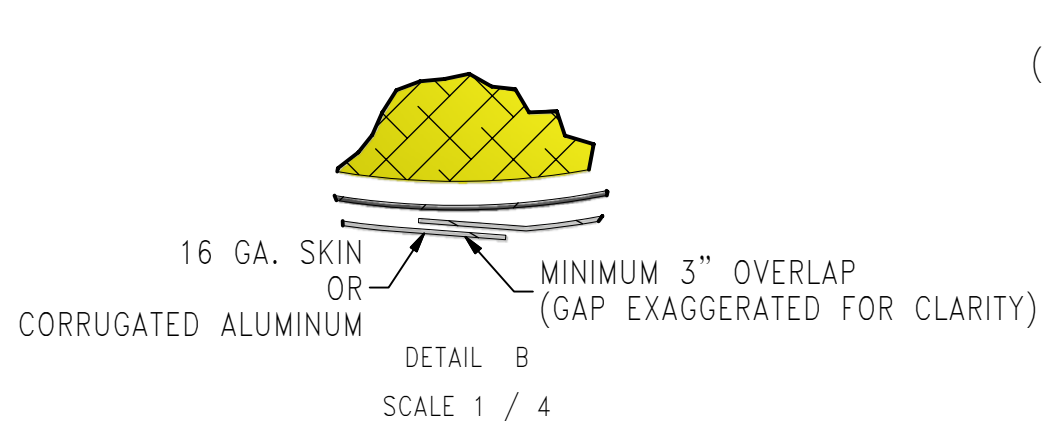

	1/1 OCTAVE BAND FREQUENCIES (HZ)							
	63	125	250	500	1K	2K	4K	8K
ALUMINUM SKIN	20	22	20	37	45	54	60	60
16 GA. GALV. SKIN	22	24	30	41	50	59	66	66

NOTE: SOUND TRANSMISSION LOSS IN DECIBELS

DATE	SYM	REVISION	DR	
-	-	-	-	
CUSTOMER:				
CUSTOMER PO#:				
CUST. SPEC#:				
QUANTITY:				
WEIGHT (LBS):		508 lbmass		
MATERIAL SPECIFICATIONS				
	MATL	CHK'D	GAGE	CHK'D
SHELL				
VANES				
LUGS				
INTERNALS				
PERFORATED				
ACOUSTIC FILL				
ACOUSTIC WRAP				
INSPECTED BY:		DATE:		
PAINT SPECIFICATIONS				
MFG:				
PREP:				
PRIME:				
COLOR:		DFT:		
INTER:				
COLOR:		DFT:		
FINISH:				
COLOR:		DFT:		
MATERIAL CERTIFICATIONS				
MATERIAL		HEAT NO.		
UNLESS OTHERWISE SPECIFIED ALL DIMENSIONS ARE IN INCHES				
DIMENSIONS IN PARENTHESES ARE REFERENCE DIMENSIONS				
ALLOWABLE TOLERANCES				
±1/16" UP TO 48"				
±3/32" OVER 48"				
THIS DOCUMENT CONTAINS MATERIAL AND/OR INFORMATION WHICH IS THE PROPERTY OF THE AEROACOUSTIC CORP. AND IS SUPPLIED ONLY ON A PROPRIETARY BASIS. NO TRANSMITTAL OR DISCLOSURE SHALL BE MADE TO ANY PERSON, FIRM OR CORPORATION WITHOUT OUR PRIOR WRITTEN APPROVAL.				
DATE	SCALE	DRAWN BY	JRR	
6/20/2009	-	CHECKED BY		
TITLE				
PART #: Lagging Detail Rep				
DRAWING NUMBER	SHEET	REV		
F--Lagging Detail Rep	1 OF 1			